

Generation of single-picosecond dye laser pulses using one- and two-photon traveling-wave excitation

A. N. Rubinov,* M. C. Richardson, K. Sala, and A. J. Alcock

Division of Physics, National Research Council of Canada, Ottawa, Canada
(Received 16 June 1975)

Single-photon and two-photon traveling-wave excitation of superradiant emission in Rhodamine 6G by single-picosecond $1.06\text{-}\mu$ laser pulses is reported. In addition, results are presented on the application of optical Kerr-effect photography to a time-resolved spectroscopic study of the dye laser emission.

PACS numbers: 42.60.E

There is considerable interest at the present time in the availability of high-power frequency-tunable ultrashort laser pulses. Actively or passively mode-locked dye lasers, employing pulsed flashlamp pumping^{1,2} or continuous laser pumping³ have been developed, and are presently capable of generating pulses of subpicosecond duration.⁴ Ultrashort dye laser pulses have also been produced by pumping with the second harmonic of mode-locked Nd:glass lasers^{5,6} and with the output of mode-locked ruby lasers.⁷ In general, the latter technique has been employed where mode-locked dye lasers of the highest peak power were required.

In this paper we wish to describe some results obtained with a dye laser which is pumped with a single-picosecond pulse derived from the output of a mode-locked Nd:glass oscillator-amplifier system. In particular, we wish to report the generation of superradiant picosecond laser pulses from Rhodamine 6G using either one- or two-photon traveling-wave excitation. Superradiant dye laser emission employing single-photon excitation by picosecond pulses from ruby lasers⁸ and nanosecond pulses from Nd:glass lasers^{9,10} has been previously reported. In addition, Lin *et al.* have recently observed picosecond laser emission from Rhodamine 6G by employing single-photon transverse pumping with the second-harmonic output of a mode-locked ruby laser.¹¹

The present study involved an analysis of the temporal and spectral characteristics of the superradiant emission from a cell of Rhodamine 6G, longitudinally pumped with either the second-harmonic or the fundamental frequency of a single 10-psec $1.06\text{-}\mu$ laser pulse having an energy of up to 700 mJ. Simultaneous temporal and spectral analysis of the pumping radiation, and of the superradiant laser emission has been obtained using picosecond optical Kerr effect photography,¹² employing a transverse-gating focal-plane shutter geometry.^{13,14} This technique has already been used in the study of the development of mode-locked Nd:glass pulses,¹⁴ and in the direct measurement of frequency chirping in such pulses.¹⁵ In this manner, the temporal development of the spectral emission of the picosecond traveling-wave dye laser has been studied as a function of dye concentration. In the case of single-photon pumping, frequency pulling effects within the picosecond pulse when the dye laser emission frequency is close to that of the pumping radiation have been noted. In addition, for weak dye laser concentrations stimulated

Raman scattering in the solvent has been observed simultaneously with the dye laser emission.

The experimental arrangement used in these studies is shown schematically in Fig. 1. The mode-locked Nd:glass laser included a 15-cm-long 10-mm-diam Brewster-angled rod, situated in a 120-cm-long optical resonator formed by a 3-m-radius-of-curvature fully reflecting mirror and a plane 50% transmitting output mirror. Mode locking was produced by the incorporation of a 4-mm-thick cell of Kodak 9740 solution in close proximity to the fully reflecting mirror. The output of this laser, which has studied in detail using picosecond streak photographic techniques¹⁶ typically consisted of a train of ~ 150 picosecond pulses, having a maximum individual pulse energy of a few millijoules. A single pulse was selected from the center of the pulse train with the aid of an electro-optic shutter, activated by a laser-triggered spark gap. The single pulse transmitted by this shutter passed through a second dye cell containing Kodak 9740 solution and then was amplified to energies up to ~ 0.7 J by double passage through a 60-cm-long 25-mm-diam amplifier. A phase-matched KDP crystal was used to convert a fraction ($\sim 10\%$) of

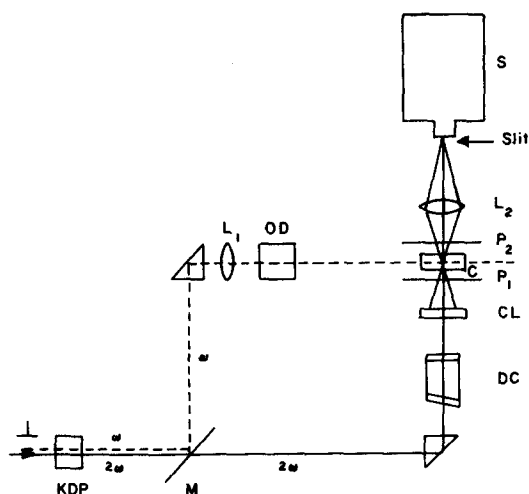

FIG. 1. Schematic of experimental setup for the time-resolved analysis of the character of picosecond dye laser pulses produced by traveling wave excitation. M, selective dielectric mirror; DC, dye laser cell; CL, cylindrical lens; OD, optical delay; C, optical Kerr-effect cell of CS₂; P₁, P₂, orthogonally oriented polarizers; L₁, L₂, lenses; S, spectrograph.

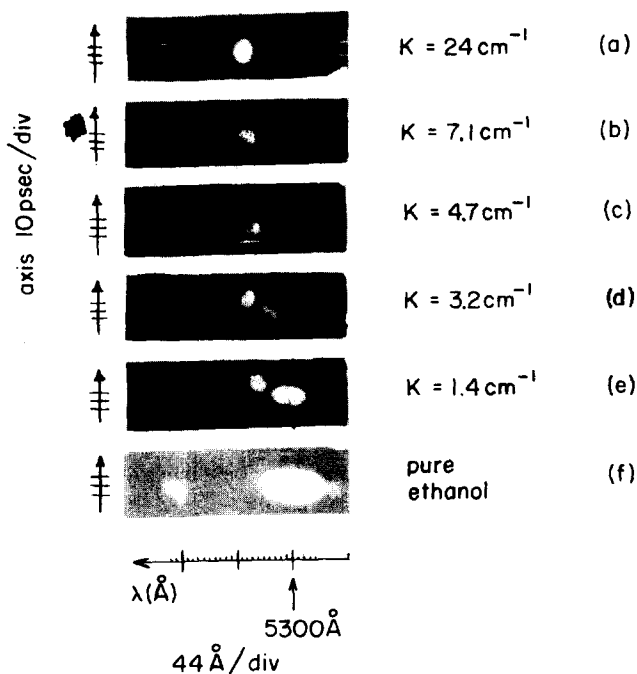

FIG. 2. Temporal and spectral character of single-photon-excited traveling-wave dye laser as a function of Rhodamine 6G concentration (K is absorption coefficient of dye solution at 5300 \AA).

the beam to second-harmonic radiation (0.53μ) and a frequency-selective mirror, M , transmitted the latter and reflected the fundamental infrared radiation.

In the case of single-photon dye laser excitation, the second-harmonic radiation was used to longitudinally pump a 2-cm-long cell of Rhodamine 6G in ethyl alcohol. The temporal and spectral characteristics of the dye laser emission were investigated by using a variation of the technique of transverse-gating focal-plane optical Kerr-effect photography previously used to analyze the output of the neodymium glass laser itself.^{14,15} The dye laser radiation was focused with a cylindrical lens into a small cell of CS_2 , situated between two crossed polarizers, oriented at 45° to the polarization axis of the gating pulse. Thus the dye laser radiation passed through the CS_2 cell as a thin sheet $\sim 1 \text{ cm}$ wide. At the same time, this pulse of radiation was probed transversely by a slightly focused pulse of $1.06\text{-}\mu$ radiation, of duration $\sim 10 \text{ psec}$, and of sufficient intensity to induce birefringence in the CS_2 . Consequently, that dye laser radiation which was coincident with the $1.06\text{-}\mu$ pulse passed through birefringent CS_2 , and therefore was partially transmitted by the second polarizer. The transmitted sheet of radiation now had a temporal shift across its width, due to the transit time of the $1.06\text{-}\mu$ pulse across the dye laser radiation in the CS_2 cell. This radiation was then focused by means of a spherical lens, L_2 , onto the slit of a $\frac{3}{4}\text{-m}$ Czerny-Turner spectrograph, such that the width of the dye laser radiation was aligned along the slit. This resulted in spectrograms with a wavelength scale in one direction and a picosecond time scale in the other.

Figure 2 shows a series of spectrograms of the superradiant emission from different concentrations of Rhodamine 6G in ethyl alcohol, pumped by the single-photon absorption of the $0.53\text{-}\mu$ second-harmonic radiation. Several features are immediately apparent. First, as can be seen from all the spectra, the duration of the dye laser emission is comparable to that of the exciting radiation ($\sim 20 \text{ psec}$). Separate measurements made with calibrated photodiodes indicated a maximum conversion efficiency of $\sim 10\%$, thus giving a peak power of the dye laser output of $\sim 350 \text{ MW}$. The spectrum of the dye laser emission is typically $\sim 120 \text{ \AA}$ wide, and shifts toward shorter wavelength as the concentration of Rhodamine 6G is reduced, as commonly occurs in this dye, due to the decreasing effect of self-absorption of the dye laser radiation. However, several other interesting features are apparent from Fig. 2. At high dye concentrations, Fig. 2(a), when the pumping radiation is absorbed in the first millimeter or so of the dye cell, and the resulting dye laser radiation then propagates through the remaining unpumped dye solution, the spectrum of the emission is symmetrical. However, in somewhat weaker solution ($K \sim 7.1 \text{ cm}^{-1}$), Fig. 2(b), a frequency sweep of $\sim 50 \text{ \AA}$ is apparent during the 20-psec pulse. Occasionally, when imperfect mode locking of the Nd:glass laser occurred, the pumping radiation consisted of more than one pulse. In this case, more than one pulse was evident in the dye laser emission, Fig. 2(c). This shows the case where two pulses, separated by $\sim 40 \text{ psec}$ were incident on the dye cell. As can be seen, the second pulse is shifted towards shorter wavelength, and is itself frequency chirped. Both these phenomena result from the progressive self-absorption after dye laser emission as the pulse propagates through the unpumped dye solution. When the dye concentration was such that the absorption length was comparable to the dye cell length, the spectrum of the resulting superradiant emission was as shown in Figs. 2(d) and 2(e). As can be seen, a fraction of the second-harmonic radiation is transmitted, Fig. 2(e). In addition, there is a frequency pulling effect over approximately 200 \AA between the second-harmonic radiation and the dye laser radiation, which is emitted approximately 15 psec after absorption of the $0.53\text{-}\mu$ light. This latter result illustrates the effectiveness of this type of picosecond time-resolved spectroscopy in the direct single-shot measurement of molecular relaxation times. Finally, at very weak dye concentrations, Fig. 2(e), and in pure ethyl alcohol, Fig. 2(f), stimulated Raman scattering¹⁷ in the solvent at 6275 \AA is observed, simultaneously with the second-harmonic emission.

Similar time-resolved spectroscopic studies of the superradiant emission from Rhodamine 6G were made using traveling-wave two-photon absorption of the fundamental radiation of the single picosecond Nd:glass laser pulse. In this case, the KDP crystal was removed, and the frequency-selective mirror M replaced by a 50% beam splitter. Superradiant emission from the Rhodamine 6G dye solution was observed, with a maximum conversion efficiency of $\sim 1\%$ at high concentration levels, with typical single-photon absorption coefficients at 5300 \AA of $K \sim 1300 \text{ cm}^{-1}$. A typical time-resolved spectrum of the superradiant emission in the

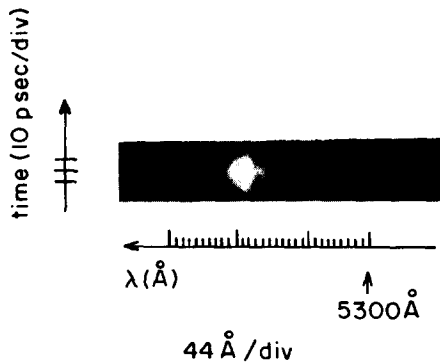

FIG. 3. Temporal and spectral character of emission of dye laser under two-photon traveling-wave excitation.

case of two-photon excitation is shown in Fig. 3. As can be seen, the dye laser emission has a duration of ~ 25 psec, implying a peak output power ~ 280 MW. Although no frequency sweeping occurs in the emission, a satellite pulse, synchronous with the main dye laser pulse, is observed at shorter wavelengths.

The foregoing results have demonstrated several interesting features: First, single-photon and two-photon traveling-wave excitation of superradiant emission in Rhodamine 6G in solution in ethyl alcohol by single picosecond pulses derived from a mode-locked Nd:glass laser are reported for the first time. Second, the application of transverse-gating focal-plane optical Kerr-effect photography¹⁸ to the time-resolved spectroscopic study of dye laser emission is demonstrated on a picosecond time scale. This technique should be applicable to the study of picosecond laser emission and the investigation of laser-induced luminescence and other phenomena occurring on a picosecond or sub-picosecond time scale.

The authors express their gratitude to P. Burtyn, K. Leopold, and W.J. Orr for their continued technical assistance.

- *On leave of absence from the Physics Institute of the Belorussian Academy of Sciences, Minsk, under the Exchange Agreement between the National Research Council of Canada and the Academy of Sciences of the USSR.
- ¹W. Schmidt and F. P. Schafer, *Phys. Lett. A* **26**, 558 (1968).
 - ²D. J. Bradley and A. J. F. Durrant, *Phys. Lett. A* **27**, 73 (1968).
 - ³A. Dienes, E. P. Ippen, and C. V. Shank, *Appl. Phys. Lett.* **19**, 258 (1971); D. J. Kuizenga, *ibid.* **19**, 260 (1971).
 - ⁴C. V. Shank and E. P. Ippen, *Appl. Phys. Lett.* **24**, 373 (1974).
 - ⁵W. H. Glenn, M. J. Brienza, and A. J. DeMaria, *Appl. Phys. Lett.* **12**, 54 (1968).
 - ⁶B. H. Soffer and J. W. Linn, *J. Appl. Phys.* **39**, 558 (1968).
 - ⁷D. J. Bradley, A. J. F. Durrant, G. M. Gale, M. Moore, and P. D. Smith, *IEEE J. Quantum Electron.* **QE-4**, 707 (1968).
 - ⁸M. E. Mack, *Appl. Phys. Lett.* **15**, 166 (1969).
 - ⁹S. L. Chin and G. Bedard, *Opt. Commun.* **3**, 299 (1971); **4**, 148 (1971).
 - ¹⁰S. L. Chin, L. Leclerc, and G. Bedard, *Opt. Commun.* **6**, 264 (1972).
 - ¹¹C. Lin, T. K. Gustafson, and A. Dienes, *Opt. Commun.* **8**, 210 (1973).
 - ¹²M. A. Duguay and J. W. Hansen, *IEEE J. Quantum Electron.* **QE-7**, 37 (1971).
 - ¹³M. C. Richardson and K. Sala, *Appl. Phys. Lett.* **23**, 420 (1973).
 - ¹⁴M. C. Richardson and K. Sala (unpublished).
 - ¹⁵A. N. Rubinov, M. C. Richardson, K. Sala, and A. J. Alcock, *Opt. Commun.* **12**, 188 (1974).
 - ¹⁶M. C. Richardson, *IEEE J. Quantum Electron.* **QE-9**, 768 (1973).
 - ¹⁷R. R. Alfano and S. L. Shapiro, *Phys. Rev. Lett.* **29**, 1655 (1972).
 - ¹⁸K. Sala and M. C. Richardson (unpublished).

Electro-optic effects in the optically active compounds $\text{Bi}_{12}\text{TiO}_{20}$ and $\text{Bi}_{40}\text{Ga}_2\text{O}_{63}$

A. J. Fox and T. M. Bruton*

Mullard Research Laboratories, Redhill, Surrey, RH1 5HA, England
(Received 10 June 1975)

The electro-optic effects in the optically active 23 class compounds $\text{Bi}_{12}\text{TiO}_{20}$ (BTIO) and $\text{Bi}_{40}\text{Ga}_2\text{O}_{63}$ (BGAO) have been investigated. Measurements were made of the electro-optic and electrogyration coefficients using longitudinal and transverse modes. Novel techniques employing a servo-driven Soleil compensator were used to obtain these coefficients. A value of $\eta = 17 \times 10^{-12}$ rad m/V was obtained for the electrogyration coefficient in the BTIO compound.

PACS numbers: 78.20.J

Crystals belonging to the γ - Bi_2O_3 family are of interest for their large electro-optic coefficients and their potential application in PROM-type¹ storage/display devices. The electro-optic effects in the Si and Ge compounds $\text{Bi}_{12}\text{SiO}_{20}$ and $\text{Bi}_{12}\text{GeO}_{20}$ have been described

by several authors.^{2,3} This letter reports work on the electro-optic effects in two other γ - Bi_2O_3 compounds, i.e., $\text{Bi}_{12}\text{TiO}_{20}$ (BTIO) and $\text{Bi}_{40}\text{Ga}_2\text{O}_{63}$ (BGAO). In particular, measurements of the linear electro-optic and electrogyration coefficients are described.